

**NOTE:**  
 1. PART MUST BE FREE OF ALL BURRS AND SHARP EDGES.  
 2. HEAT TREAT TO SPRING TEMPER AT 600° F. FOR 2 1/2 - 3 HRS AFTER STAMPING.

BNN3-PS-NB-LF  
 LEADFREE  
 RoHS Compliant

**NOTES:**  
 1. REMOVE ALL BURRS AND SHARP EDGES.  
 2. ALL DIAMETERS TO BE CONCENTRIC.  
 3. MAT'L:  
 BRASS, CDA 360, 385 OR EQUIVALENT

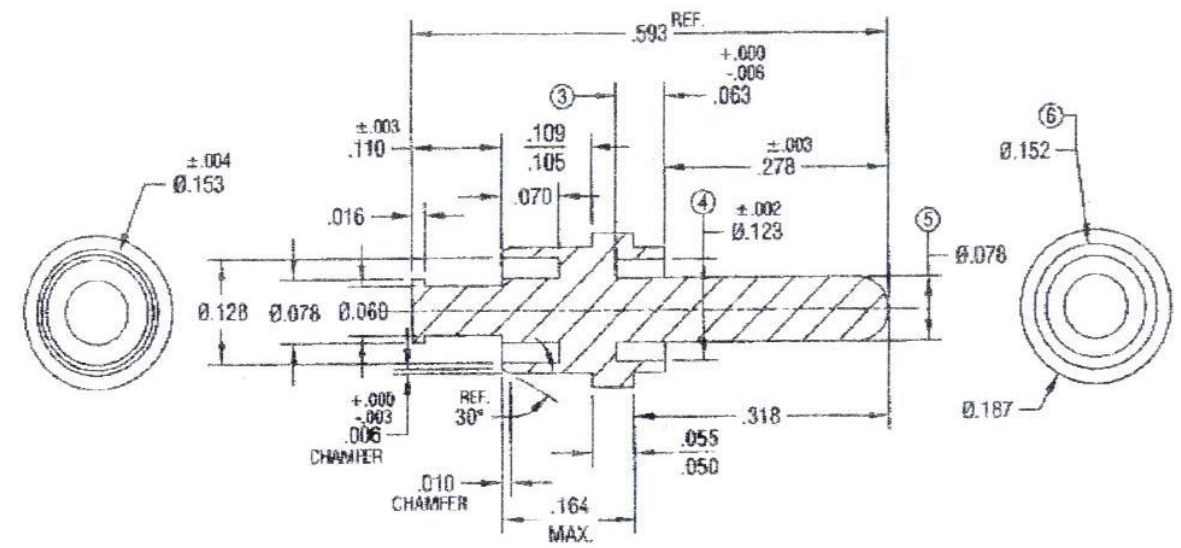

**MORETHANALL**  
 CONNECTORS  
 ASSEMBLIES

PART NO. BNN3-PS-NB

DWG NO. BNN3-PS-NB

FILE NO.

CHECKED BY CY

DRAWING BY

PROJECTION

TOLERANCES ARE  
 .X ± 0.2  
 .XX ±  
 .XXX ±  
 AWG

DESCRIPTION:			
AREA	REVISIONS	HK	DATE

煜倫股份有限公司

UNIT / mm SCALE 1:1