

BNC-PCR26-xx

58=RG/58U  
59=RG/59U  
6=RG/6U

	A	B	C	D
RG/58U	∅3.2	∅4.6	∅5.6	∅6.5
RG/59U	∅3.9	∅5.6	∅6.4	∅7.3
RG/6U	∅5.1	∅6.5	∅7.5	∅8.2

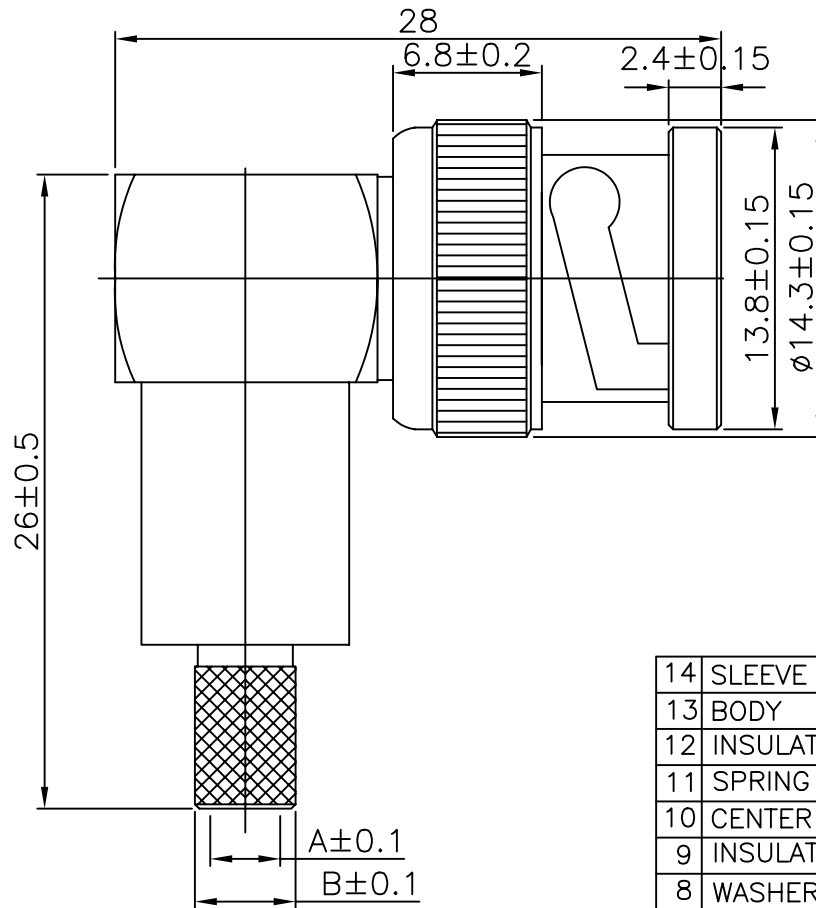

14	SLEEVE	BRASS	NICKEL	1
13	BODY	BRASS	NICKEL	1
12	INSULATOR	POM	NONE	1
11	SPRING	BRASS	NICKEL	1
10	CENTER CONTACT	BRASS	NONE	1
9	INSULATOR	POM	NONE	1
8	WASHER	FE	NICKEL	1
7	SPRING	FE	NONE	1
6	RUBBER WASHER	PVC	NONE	1
5	OUT CONTACT	ZINC	NICKEL	1
4	INSULATOR	POM	NONE	1
3	CENTER CONTACT	BRASS	GOLD	1
2	SHELL	ZINC	NICKEL	1
1	BODY	BRASS	NICKEL	1
NO	DESCRIPTION	MATERIAL	FINISH	QTY

**MORETHANALL**  
CONNECTORS  
ASSEMBLIES

焯倫有限公司

PART NO. BNC-PCR26-xx

DWG NO. BNC-PCR26-xx

FILE NO.

UNIT / mm

SCALE 1:1

CHECKED BY CY

DRAWING BY

PROJECTION

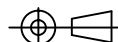

TOLERANCES ARE

0.5-5 =±0.2  
5-30 =±0.4  
30-120 =±0.6  
120-315 =±1  
315-1000 =±1.6  
1000-2000 =±2.4

DESCRIPTION:

BNC MALE RIGHT ANGLE CRIMP  
TYPE

AREA

REVISIONS

HK

DATE