

RECOMMENDED MOUNTING HOLE

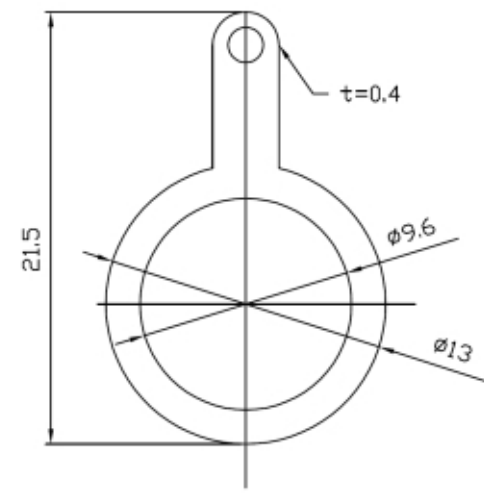
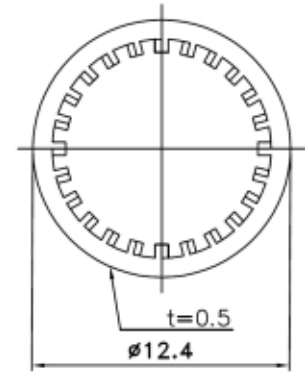
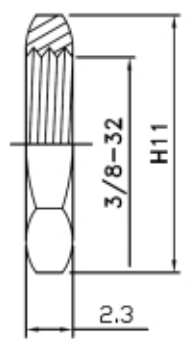

BNC-JSPAZA33-xx-LF
LEADFREE
50:50/OHM
75:75/OHM
RoHS Compliant

NO	DESCRIPTION	MATERIAL	FINISH	QTY
6	GROUND LUG	STEEL	NICKEL	1
5	NUT	STEEL	NICKEL	1
4	WASHER	STEEL	NICKEL	1
3	INSULAROT	TEFLON	NONE	1
2	PIN	BRASS	GOLD	1
1	BODY	ZINC	NICKEL	1

MORETHANALL
CONNECTORS
ASSEMBLIES

PART NO. BNC-JSPAZA33-xx

DWG NO. BNC-JSPAZA33-xx

FILE NO.

UNIT / mm

SCALE 1:1

CHECKED BY CY

DRAWING BY

PROJECTION

TOLERANCES ARE

.X ± 0.2
.XX ± 0.1
.XXX ±
AWG

DESCRIPTION:

AREA

REVISIONS

HK

DATE

焯倫股份有限公司