

- ◆ Assembly dim.
- Functionally dim.
- Control dim.

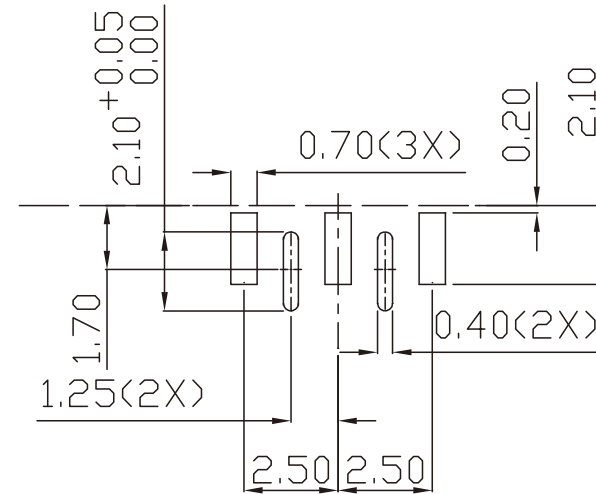
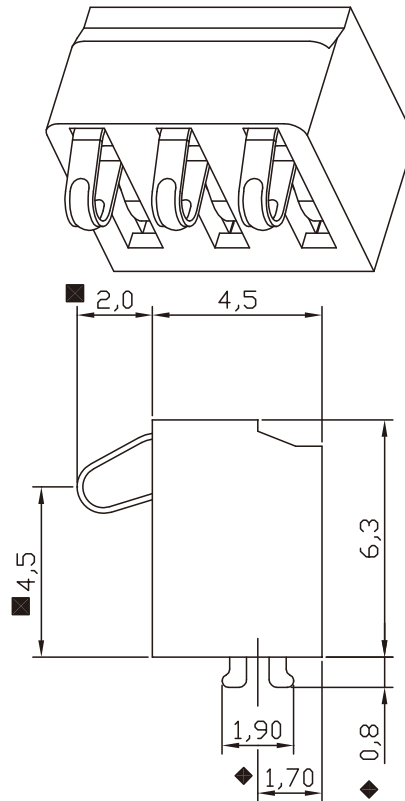
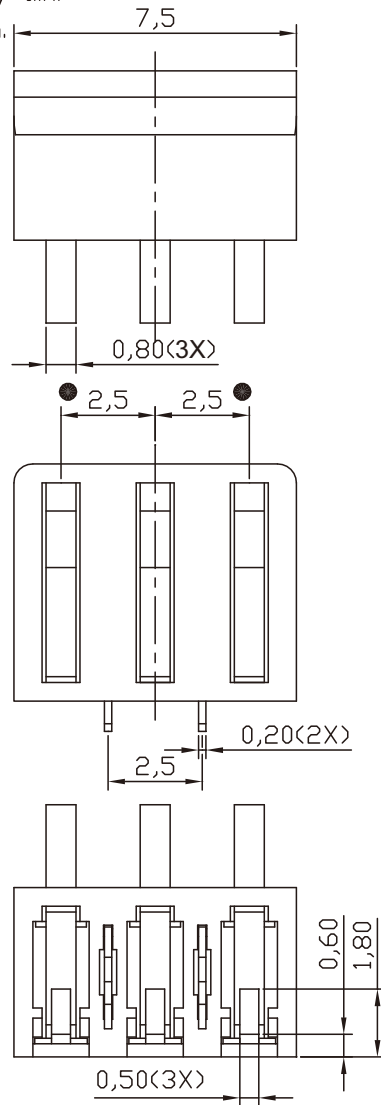

<SUGGESTED PCB LAYOUT>

Notes:

1. Material:
 - 1-1. Housing: LCP, Black, UL94V0.
 - 1-2. Contact: Copper Alloy, Au 30u", Sn 150~200u", Ni 50~90u".
 - 1-3. Soldering Pin : Stainless steel, Sn 150~200u", Ni 50u" min.
2. Normal Force: 380g Min.(3Pins) when 1.0mm stroke.
3. Life Cycle: 5,000 min.
4. Current Capacity: 1.0A
- 5. Coplanarity: 0.10mm Max.
6. Standard ACT SMD Package.

RoHS Compliant

TOLERANCES ARE

MORETHANALL
PCB CONNECTORS
Cable ASSEMBLIES

煜倫股份有限公司

www.morethanall.com

DRAWING BY CY

CHECKED BY GENIUS

UNIT / mm SCALE 1 : 1

DATE

SIZE A4

X. ±
.X ±
.XX ±
.XXX ±
ANG ±

PJECTION

照片框

ORDER INFORMATION

BCS25-W63ZR-03-LF

SERIES | | | | LEADFREE
03 WAY
REEL
CLIP
HIGH 6.30mm
90°SMT

DESCRIPTION: 3pins Battery Conn. Pitch=2.5mm

- ◆ Assembly dim.
- Functionally dim.
- Control dim.

CARRIER TAPE WAY OUT

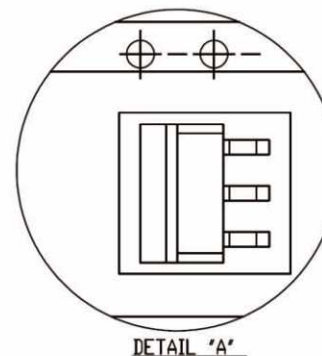
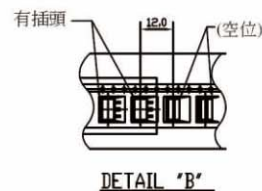
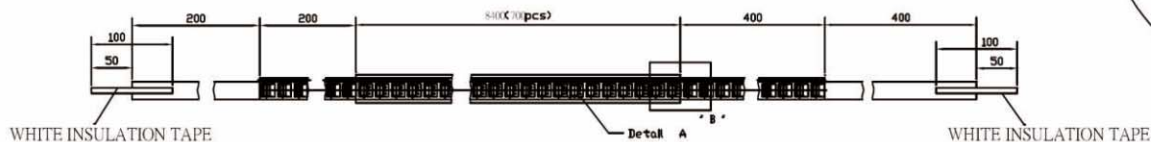

NOTE:

- 7.PACKAGING INSTRUCTIONS

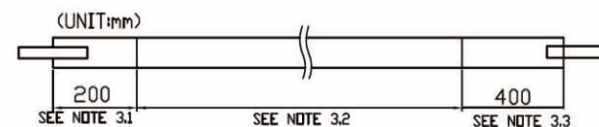

7.1 CARRIER TAPE END ATTACHED TO THE REEL(W/O CONN.)

7.2 EMPTY(CONNECTOR)

7.3 CARRIER TAPE END(W/O CONN.)

- 8. THE SEPARATION FORCE BETWEEN COVER TAPE AND CARRIER TAPE
SEPARATION FORCE : 15 gf - 80 gf
TEARING DIRECTION AND ANGLE

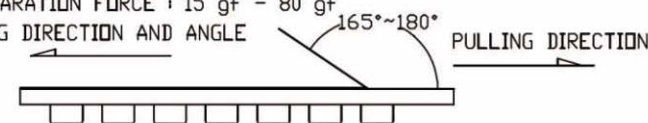

9. 700 PCS/PER PLASTIC REEL

10 ATTACH QUALIFIED LABEL ACCORDING TO THIS DRAWING

11 EACH REEL NEEDS STICKING 3 PIECES INSULATION TAPE,(L=10cm)

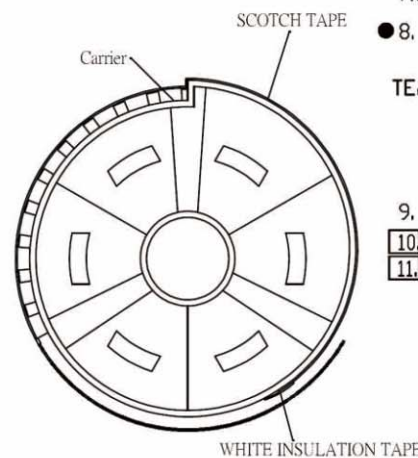
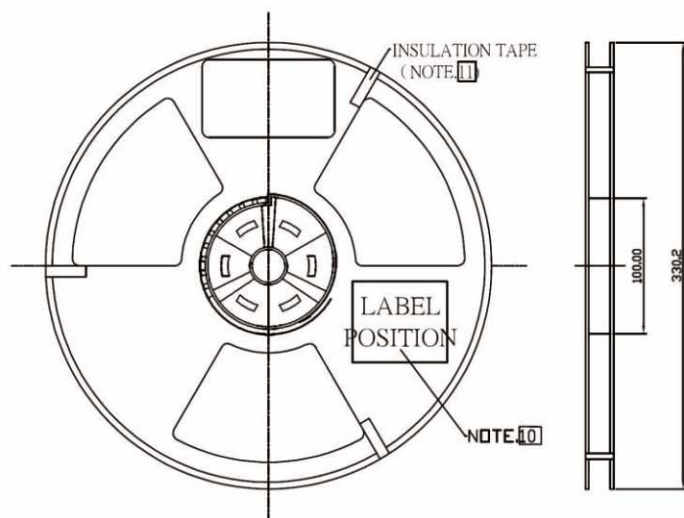

PACKAGE WAY

RoHS Compliant

TOLERANCES ARE

MORETHANALL
PCB CONNECTORS
Cable ASSEMBLIES

煜倫股份有限公司

www.morethanall.com

DRAWING BY CY

CHECKED BY GENIUS

UNIT / mm SCALE 1 : 1

DATE

SIZE A4

X, ±
.X ±
.XX ±
.XXX ±
ANG ±

PJECTION

照片框

ORDER INFORMATION

BCS25-W63ZR-03-LF

SERIES | | | | LEADFREE
| | | | 03 WAY
| | | | REEL
| | | | CLIP
| | | | HIGH 6.30mm
| | | | 90°SMT

DESCRIPTION: 3pins Battery Conn. Pitch=2.5mm