

SECTION A-A

- NOTES:  
 1.MATERIAL:  
 HOUSING:THERMOPLASTIC, HIGH TEMP, 30% G/F UL94 V-0  
 COLOR:BLACK  
 TERMINAL:C5210R PHOSPHOR BRONZE FAR SPRING (SH),T=0.15mm  
 PEG:BRASS C2680-H,T=0.20mm  
 2.FINISH:  
 TERMINAL: 15μ" GOLD PLATING ON CONTACT AREA  
 50μ" MIN.NICKEL UNDERPLATING OVER ALL  
 PEG:100u" MIN.TIN PLATING ON SOLDER TAILS  
 50u" MIN.NICKEL UNDERPLATING OVER ALL

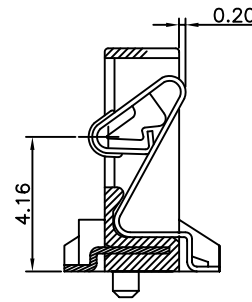

Battery contacts

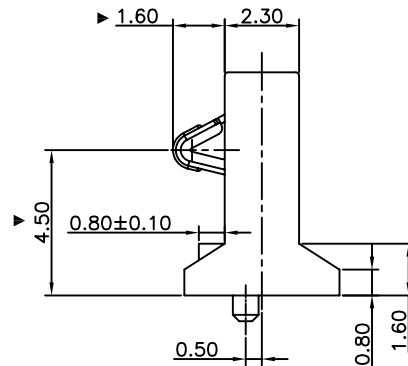
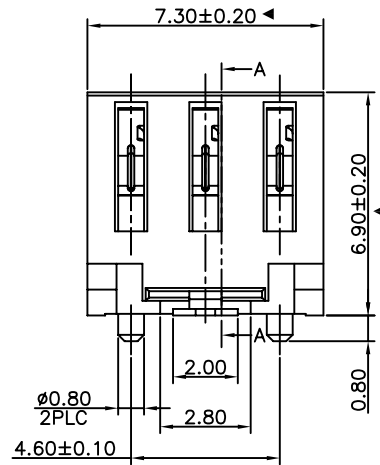
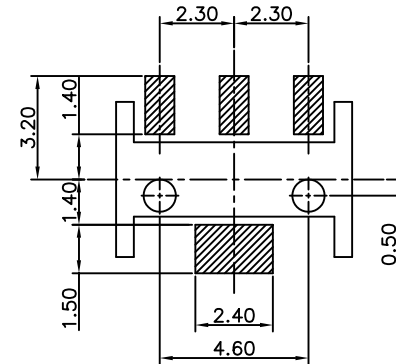

RECOMMEND P.C.BOARD LAYOUT

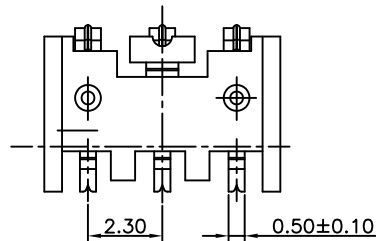

BCS23-W69P-03-LF  
 LEADFREE

RoHS Compliant

**MORETHANALL**  
 CONNECTORS  
 ASSEMBLIES

PART NO. BCS23-W69P-03

DWG NO. BCS23-W69P-03

CHECKED BY CY

TOLERANCES ARE

DESCRIP TION:

BATTERY 3P STRAIGHT SMT TYPE

FILE NO.

DRAWING BY

.X ± 0.2  
 .XX ± 0.1  
 .XXX ±  
 AWG

AREA

REVISIONS

HK

DATE

煜倫股份有限公司

UNIT / mm

SCALE 1:1

PROJECTION

