

# SPECIFICATION

- Description** : Dual Band Antenna
- Standard** : IEEE 802.11a+b/g Wireless LAN
- Antenna Profile** : 108.5 mm length (see Drawing)
- Color** : Black
- Electrical Characteristics**
  - Operating Frequency : 2.4~2.5 / 5.15~5.35 / 5.725~5.85GHz
  - Antenna Type : Dipole Sleeve
  - Polarization Type : Linear
  - Type of Radiation : Toroidal
  - Peak Gain : 2.0 dBi Typical
  - Impedance : 50 Ohm nominal
  - V.S.W.R. : 2.0:1 Max.
- Mechanical Characteristics**
  - Action : Swivel Type
  - Connector : RP-SMA (M)
  - Core : N/A
- Raw Material**
  - Coaxial Cable : RG-178
  - Housing : TPU
  - Hinge : PC+ALLOY/POM

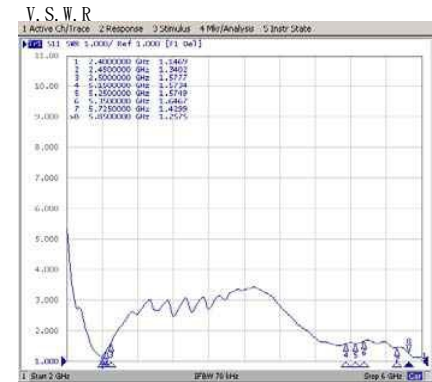

Radiation Pattern - E Plane

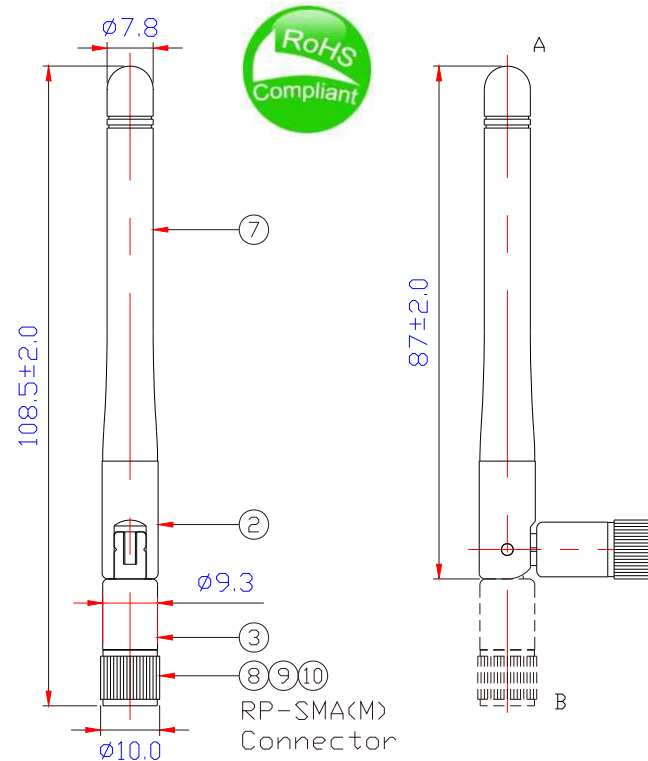
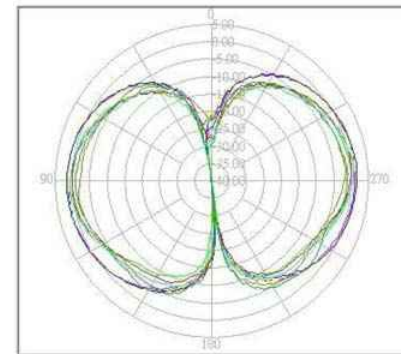

Radiation Pattern - H Plane

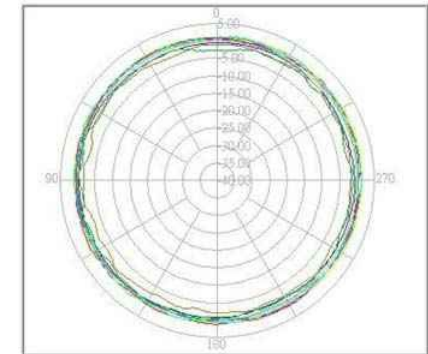

11	Reverse SMA φ 10 Body	Body SMA CONNECTOR φ 10 W/P	Black	1	or Equivalent
10	Reverse SMA φ 10 PIN Isolator	SMA CONNECTOR 10 φ female PIN		1	or Equivalent
9	Reverse SMA φ 10 Shaft	L=8.7 φ 4.7 Shaft	silver	1	or Equivalent
8	Housing	9.3 φ *75L(67L) Housing	Black	1	or Equivalent
7	Heat Shrink Tube	H-2(CB) φ 5.0	Black	1	or Equivalent
6	Sleeve	4.8 φ *24L Sleeve	silver	1	or Equivalent
5	Sleeve	5.2 φ *24L*0.2T Sleeve	silver	1	or Equivalent
4	Rivet	3.80*1.90 φ Rivet	Black	2	or Equivalent
3	Hinge-Base	9.3 φ Hinge-Base(6.6 φ)	Black	1	or Equivalent
2	Hinge-Holder	9.5 φ *20.0L Hinge-Holder	Black	1	or Equivalent
1	RG-178 Coaxial Cable	RG-178 CABLE 105SV	Orange	1	or Equivalent
NO	Material	Description	Color	Q'ty	Remark

RoHS Compliant

TOLERANCES ARE

**MORETHANALL**  
PCB CONNECTORS  
Cable ASSEMBLIES

DRAWING BY CY

CHECKED BY GENIUS

UNIT / mm SCALE 1 : 1

DATE

SIZE A4

PJECTION

X, ±  
.X ±  
.XX ±  
.XXX ±  
ANG ±

照片框

煜倫股份有限公司

www.morethanall.com

ORDER INFORMATION

ANTRPSMA-1S1F2B-M10C8-LF

SERIES

ST

MALE  
2 BAND  
FOLDABLE

108.5mm

LEADFREE

DESCRIPTION: