

備注/NOTE

1. “△”為重點尺寸。

規格/SPECIFICATION

2. 電氣特性 / ELECTRICAL CHARACTERISTICS: 絕緣耐壓 / DIELECTRIC WITHSTANDING VOLTAGE: 100V AC.

絕緣阻抗 / INSULATION RESISTANCE: 100 MEGOHMS MIN.

接觸電壓 / CONTACT VOLTAGE: 30V MAX.

接觸阻抗 / CONTACT RESISTANCE: 50 MILLIOHMS MAX.

負載 / CONTACT CURRENT RATING: 1.5 AMPERES.

3. 環境 / ENVIRONMENTAL.

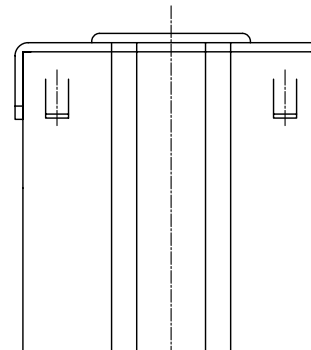

操作溫度 / OPERATING TEMPERATURE
-40°C to +85°C.

4. 材質 / MATERIAL:

- 4-1. 膠芯 / HOUSING: NYLON 6T
- 4-2. 針 / PIN: 磷銅 / PHOSPHOR BRONZE
- 4-3. 內殼 / INNER SHELL: 青銅 / BRASS
- 4-4. 外殼 / SHELL: 青銅 / BRASS
- 4-5. 外殼上蓋 / SHELL: SHELL

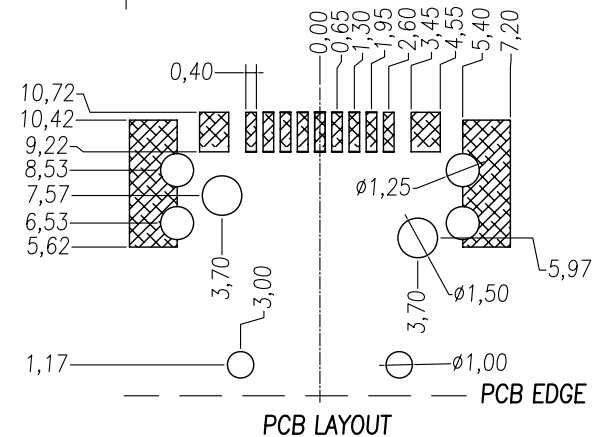

1394BE-SW2-09-LF
LEADFREE

RoHS Compliant



PART NO. 1394BE-SW2-09

DWG NO. 1394BE-SW2-09

FILE NO.

CHECKED BY CY

DRAWING BY

TOLERANCES ARE

.X ± 0.1

.XX ± 0.05

.XXX ±

AWG

DESCRIPTION: 1394-9PIN

煜倫股份有限公司

UNIT / mm

SCALE 1:1

PROJECTION

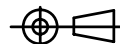

AREA

REVISIONS

HK

DATE